

User Guide
MS 100 Multisensor
Temperature, Humidity and Brightness
for 1-Wire Bus system

- High-quality Multisensor for temperature and rel. humidity with 12 Bit resolution
- Light sensor for detection of ambient brightness
- Voltage monitoring integrated
- Equipped with original DS2438 chip
- Mounting on flush-mounted boxes possible
- Universal surface mounting
- Shapely and high quality sensor housing with integrated ventilation slots
- Connection via screw terminals
- Simple power supply (5V)



Application

- Temperature sensor for individual room control
- Control sensor for ventilation system
- Monitoring of living spaces for mold risk

Note

Before you start assembling the device and put it into operation, read these operating instructions through to the end, especially the section on safety instructions.

1 Product description

With the MS 100 1-Wire Multisensor you have purchased a professional Multisensor.

Due to the most modern sensor elements, the accuracy of the MS 100 Multisensor of the rel. humidity measured values is on average 50% - 100% higher, compared to most sensors on the market.

A Brightness sensor is used to measure the twilight and brightness values within living spaces. A special photodiode with a human-like detection light spectrum is used.

The MS 100 is installed in a shapely surface-mounted housing and fits harmoniously into modern furnished living and business rooms.

Thanks to the generous ventilation openings, the 1-Wire Multisensor detects the climate conditions in rooms very directly and quickly. For all types of radiator and heating controls, an accurate Temperature sensor such as the one installed in the Multisensor is an important component.

In combination with 1-Wire ESERA Switching modules / binary outputs, a very effective and energy-saving heating control (single room control) is possible.

The Multisensor is also optimal to warn of possible mold formation.

The MS 100 Multisensor is intended for use in normal living spaces. For outdoor use and in damp rooms, such as sauna or steam bath, a suitable sensor is available from the ESERA website.

Calibration of the internal sensors is not necessary. The device can be put into operation immediately without waiting time. The electrical connection to the 1-Wire Bus system of the MS 100 is done with screw terminals and can be operated in standard mode with 3 cables for ground, data and 5V.

Each MS 100 Multisensor has an individual serial number.

The Multisensor contains an original 1-Wire chip of the type DS2438..

Note

Basics and Tips on the 1-Wire Bus system can be found in the ESERA Online Shop under 1-Wire Basics or please refer to our eBook in the Shop under Training/ Documentation

2 Technical data

design	Standard Multisensor for temperature, rel. humidity and brightness.
temperature measuring range, accuracy	-30°C to +60°C (sensor element: -55°C to +125°C) +/- 0,5° in the range from -10°C to + 85°C
Humidity sensor design, measuring range, accuracy	capacitive sensor, resolution 9 Bit 0-100% typical +/-3,5 % (10-85% rF), +/-6% (<10% and >85% rF)
Brightness sensor design, measuring range, accuracy	sensor, adapted to the sensitivity of the human eye approx. 2 - 7000 Lux +/-25% in the range up to approx. 200 Lux, +/-15% in the range up to 7000 Lux
Auto-E-Connect Support	No support of Auto-E-Connect
Operating voltage, current consumption	5VDC (+/-10%), approx.2mA
Data interface	1-Wire Bus (5V, data and ground), Original DS2438 Chip No parasitic operation possible due to reverse polarity and overvoltage protection
Protection circuits	High quality overvoltage protection of the 1-Wire data line up to permanent 28VDC voltage. Reverse polarity and overvoltage protection for power supply
connection	screw terminal for cable solid 0,2 to 2,5qmm or fine stranded 0,2 to 1,5qmm For connection we recommend slotted screwdriver size 2,5x75

3 Ambient conditions

Temperature, operation	-30°C to 60°C
Air humidity	10 - 92% (non condensing)
Dimensions	71 x 71 x 32mm (LxWxH)
Protection class	III
Protection system	IP20
Auto-E-Connect Support	No Auto-E-Connect Support

4 Conformity

EN 50090-2-2
 EN 61000-4-2, ESD
 EN 61000-4-3, HF
 EN 61000-4-4, Burst
 EN 61000-4-5, Surge
 EN 61000-6-1, Interference immunity
 EN 61000-6-3, Interference radiation
 RoHS

5 Connection diagram

The connection diagram is available in the store as a separate document.
 The Temperature and Humidity Sensor is connected by screw terminals.
 The pin assignment of the screw terminals is printed on the printed circuit board.

Assignment

The Multisensor has to be supplied with three cables (ground, 1-Wire Data and 5V). The parasitic mode is not supported.

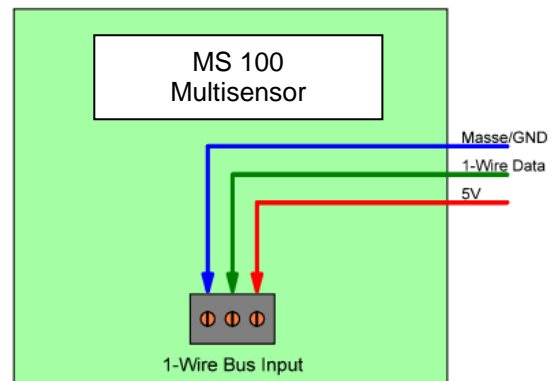

Note

The module may only be operated at the voltages and under the ambient conditions specified for it. The modules may only be commissioned by a qualified electrician.

Please observe the specified operating position of the device.

For further information on the operating conditions, see the following instructions under "Operating conditions".

Due to the high quality reverse polarity and overvoltage protection no parasitic operation is possible.

Note on brightness measurement

Please note that due to the positioning of light sources in relation to the angle of incidence of the Multisensor, there may be considerable deviations in the measured brightness values of hand-held brightness meters.

In the case of lighting with fluorescent or LED lamps, the value may also fluctuate. A living room brightness control is usually impaired by strongly changing light conditions, e.g. by shadows of people in the room and the resulting fluctuations of the sensor light values, and a well-functioning control function is often difficult to implement. The reason for this is largely the unfavorable placement in the light switch area for the brightness measurement of the Multisensor.

6 Software / Control

The Living room Sensor is read out via 1-Wire commands for DS2438 devices and supported by many systems, such as ESERA 1-Wire Controller, ESERA 1-Wire Gateway, Loxone PLC, WAGO PLC (via OWOS), OWFS, FHEM (Linux), IP-Symcon or microcontroller applications.

7 Control via 1-Wire Controller / ECO 1-Wire Controller

The control and data output of the MS 100 Multisensor via the 1-Wire Controller / 1-Wire Gateway is very simplified. The current sensor data is output continuously. No query of the data is necessary and available. If you have assigned the article number (11134) to the OWD number of this sensor via the ESERA Config Tool 3, you will receive data records adapted to the sensor from now on. Thus no further formulas are necessary.

7.1 Data output 1-Wire Controller / ECO 1-Wire Controller

The following data formats are output for the ESERA modules. If you divide the value by 100, you get the data with two decimal places.

Data output

1_OWD1_1 2008	=> Controller No._module No._data set temperature (°C) example: 20,08 °C
1_OWD1_2 100	=> Controller No._module No._data set Power Good for the operating voltage 100 = operating voltage ok, 0 = operating voltage too low
1_OWD1_3 850	=> Controller No._module No._data set air humidity (rF) example 85,0%
1_OWD1_4 1200	=> Controller No._module No._data set dew point (°C) example: 12,00 °C
1_OWD1_5 80000	=> Controller Nr._ module No._data set brightness (Lux) example: 800,00 Lux

For further information on the options and commands, please refer to the current Programming Manual of the 1-Wire Controller / 1-Wire Gateway, which can be found within Config Tool 3.

8 Integration in IP-Symcon

For the integration of the 1-Wire Controllers a suitable ESERA module for all sensors and controllers is available in the IP-Symcon module store. This can be found via the backend of the 1-Wire software (from V5.0).

Alternatively, the ESERA IP-Symcon software module for easy integration of the sensor into IP-Symcon and 1-Wire controllers is available via our website. No scripts are necessary anymore.

Details can be found on the ESERA website under "Compatible controllers / control units/IP-Symcon integration".

<https://www.esera.de/service-support/kompatible-steuerungen-zentralen/ip-symcon-integration/>

For the conventional connection via 1-Wire Bus Coupler you can find a script in the article download area.

9 Integration in Loxone

Via the shop we provide a sample project for reading in temperature, humidity values, dew point, brightness and operating voltage via 1-Wire Controller / 1-Wire Gateway.

Details see here:

<https://www.esera.de/service-support/kompatible-steuerungen-zentralen/loxone-integration/>

10 Integration in FHEM

Integration into the open source automation software FHEM is now very easy via 1-Wire controller. Since 2020, ESERA 1-Wire controllers, sensors and actuators are supported by FHEM by default. Details can be found on the FHEM website under the keyword "ESERA" or the following link:

https://fhem.de/commandref_DE.html#EseraOneWire

This means that evaluation scripts are no longer necessary.

Details can be found on the ESERA website under "Compatible controllers / control units/FHEM integration"

<https://www.esera.de/service-support/kompatible-steuerungen-zentralen/fhem-integration/>

11 Manual calculation of the sensor values

The following formula can be used to evaluate the humidity sensor.

VDD = operating voltage (5V), VAD = humidity sensor, analog value of the DS2438, Xsense = light sensor, analog value of the DS2438.

Humidity calculation

Offset = 0.847847 (Zero Offset V), slope = 29.404604 (Slope: mV/ %RH)

Srh = (VAD_new - offset) / (slope / 1000)

rFH = (SrH + 2) / ((1.0305 + (0.000044 * Temperature) - (0.0000011 * Temperature x 10²))))

for Loxone control:

I1 = VAD-Value, I3 = Temperature

(((5/I2*I1)-0,847847)/(29,404604/1000))+2)/((1,0305+(0,000044*I3)-(0,0000011*I3^2)))

Brightness calculation

Xsense in Volt, factor = 25600

correction for operating voltage fluctuations: Xsense = (5 / VDD) * Xsense

brightness (LUX) = (0,223V - Xsense) * factor

Note on brightness measurement

It should be noted that due to the placement of light sources in relation to the angle of incidence of the Multisensor, there may be considerable deviations in the measured brightness values compared to hand-held brightness meters. This is not a fault of the Multisensor.

In the case of lighting with fluorescent or LED lamps, the value may also fluctuate. A living room brightness control is usually affected by strongly changing light conditions, e.g. by shadows of people in the room and the resulting fluctuations of the sensor light values, and a well-functioning control function is often difficult to implement. The reason for this is largely the unfavorable placement in the light switch area for the brightness measurement of the Multisensor.

12 1-Wire Network, Cabling

The special feature of the 1-Wire system is the "BUS technology". All devices (sensors and actuators) are operated in parallel on a three-wire line, which is used for both power supply and data communication. The 1-Wire Bus system joins the list of other successful bus systems such as CAN or Modbus RTU. All of the installation principles recommended for these are also applicable and appropriate to 1-Wire.

The maximum size of a 1-Wire Network is determined by various factors. These are mainly:

- Total cable length and cable type
- Number of 1-Wire devices
- Type of cable installation (topology)
- Number and design of cable connectors (unnecessary connection transitions should be avoided)

All factors in total are summarised and designated as 1-Wire Bus load. Each increase in a factor increases the total 1-Wire Bus load for the 1-Wire Controller and thus reduces the maximum network size.

According to our many years of experience and a lot of feedback from customers, the following conservative recommendation can be made:

- Maximum cable length 50 -120m
- Number of 1-Wire devices no more than 20 -22 pieces
- As linear a topology as possible without T-junctions

The topology in particular plays a major role. If possible, it should be installed in a linear topology. The linear topology can be compared like pearls on a pearl necklace. The data line should be laid from one device to the next without T-joints.

Furthermore, the type of cable used can also be mentioned here. We recommend for the cabling CAT5 or CAT6 network cable. It is also possible to use J-Y(St)Y telephone cables and KNX cables. Longer cable runs are possible with CAT5 versus CAT7 cables.

With twisted pair cables, a longer connection length can be achieved in an undisturbed environment, as the capacitive Bus load is lower. A total length of 50 m and more can be easily achieved without additional measures.

In disturbed, commercial and industrial environments, the cable should always be shielded in order to increase the "robustness" or interference sensitivity of the system.

Note

The above statements on 1-Wire are hints and tips and do not describe any product property or represent any guaranteed product property of the product and the 1-Wire Controllers. Information on the basics and tips on the 1-Wire Bus system can also be found in the ESERA Online Shop under <https://www.esera.de/1-wire-grundlagen/>

13 Operating conditions

The module may only be operated at the voltages and under the ambient conditions specified for it. The operating position of the device is arbitrary. The device is intended for use in dry and dust-free rooms. If condensation forms, wait for an acclimatization period of at least 2 hours. Do not operate the module in an environment where flammable gases, vapors or dusts are or may be present.

14 Assembly

The Multisensor is to be mounted upright, with the ventilation openings at the top and bottom. It is intended for measuring the temperature and humidity of air and gases in indoor areas such as living rooms, offices, factory halls or public facilities. The measured values specified under technical data are limit data for the entire 1-Wire Multisensor and must not be exceeded or fallen short of, otherwise the Multisensor may be damaged.

15 Disposal note

Do not dispose of the unit in household waste! Electronic devices must be disposed of at the local collection points for electronic devices in accordance with the Directive on Waste Electrical and Electronic Equipment!



16 Safety instructions

When using products that come into contact with electrical voltage, the valid VDE regulations must be observed, especially VDE 0100, VDE 0550/0551, VDE 0700, VDE 0711 and VDE 0860

- All final or wiring work must be carried out with the power turned off.
- Before opening the device, always unplug or make sure that the unit is disconnected from the mains.
- Components, modules or devices may only be put into service if they are mounted in a contact proof housing. During installation they must not have power applied.
- Tools may only be used on devices, components or assemblies when it is certain that the devices are disconnected from the power supply and electrical charges stored in the components inside the device have been discharged.
- Live cables or wires to which the device or an assembly is connected, must always be tested for insulation faults or breaks.
- If an error is detected in the supply line, the device must be immediately taken out of operation until the faulty cable has been replaced.
- When using components or modules it is absolutely necessary to comply with the requirements set out in the accompanying description specifications for electrical quantities.
- If the available description is not clear to the non-commercial end-user what the applicable electrical characteristics for a part or assembly are, how to connect an external circuit, which external components or additional devices can be connected or which values these external components may have, a qualified electrician must be consulted.
- It must be examined generally before the commissioning of a device, whether this device or module is basically suitable for the application in which it is to be used.
- In case of doubt, consultation with experts or the manufacturer of the components used is absolutely necessary.
- For operational and connection errors outside of our control, we assume no liability of any kind for any resulting damage.
- Kits should be returned without their housing when not functional with an exact error description and the accompanying instructions. Without an error description it is not possible to repair. For time-consuming assembly or disassembly of cases charges will be invoiced.
- During installation and handling of components which later have mains potential on their parts, the relevant VDE regulations must be observed.
- Devices that are to be operated at a voltage greater than 35 VDC / 12mA, may only be connected by a qualified electrician and put into operation.
- Commissioning may only be realized if the circuit is built into a contact proof housing.

- If measurements with an open housing are unavoidable, for safety reasons an isolating transformer must be installed upstream or a suitable power supply can be used.
- After installing the required tests according to DGUV / regulation 3 (German statutory accident insurance, https://en.wikipedia.org/wiki/German_Statutory_Accident_Insurance) must be carried out.

17 Warranty

ESERA GmbH guarantees that the goods sold at the time of transfer of risk to be free from material and workmanship defects and have the contractually assured characteristics. The statutory warranty period of two years begins from date of invoice. The warranty does not extend to the normal operational wear and normal wear and tear. Customer claims for damages, for example, for non-performance, fault in contracting, breach of secondary contractual obligations, consequential damages, damages resulting from unauthorized usage and other legal grounds are excluded. Excepting to this, ESERA GmbH accepts liability for the absence of a guaranteed quality resulting from intent or gross negligence. Claims made under the Product Liability Act are not affected.

If defects occur for which ESERA GmbH is responsible, and in the case of replacement goods, the replacement is faulty, the buyer has the right to have the original purchase price refunded or a reduction of the purchase price. ESERA GmbH accepts liability neither for the constant and uninterrupted availability of the ESERA GmbH or for technical or electronic errors in the online offer.

We develop our products further and we reserve the right to make changes and improvements to any of the products described in this documentation without prior notice. If you need documentation or information about older product versions, contact us by email at info@esera.de.

18 Trademarks

All mentioned designations, logos, names and trademarks (including those which are not explicitly marked) are trademarks, registered trademarks or other copyright or trademarks or titles or legally protected designations of their respective owners and are hereby expressly recognized as such by us. The mention of these designations, logos, names and trademarks is made for identification purposes only and does not represent a claim of any kind on the part of ESERA GmbH on these designations, logos, names and trademarks. Moreover, from their appearance on ESERA GmbH webpages it cannot be concluded that designations, logos, names and trademarks are free of commercial property rights.

ESERA and Auto-E-Connect are registered trademarks of ESERA GmbH.

Auto-E-Connect is registered by ESERA GmbH as a German and European Patent.

19 Contact

ESERA GMBH
Adelindastrasse 20
87600 Kaufbeuren
GERMANY
Tel.: +49 8341 999 80-0
Fax: +49 8341 999 80-10
www.esera.de
info@esera.de
WEEE-Number: DE30249510